

MATERIAL SPECIFICATIONS

RECOMMENDED
BASE METAL - CDA-210, GILDING EXTRA SPRING TEMPER
PLATING - 0.0050±0.0025 MM THICK TIN

MINIMUMS
ELECTRICAL CONDUCTIVITY - ≥20% IACS AT 20°C. USE OF A MATERIAL WITH CONDUCTIVITY <20% IACS MUST BE APPROVED BY PACKARD ELECTRIC MATERIALS ENGINEERING.
TENSILE STRENGTH - 407 MPa

PLATING - FOR LOW ENERGY (≤5v) AND NON-PASSENGER COMPARTMENT POWER CIRCUITS, 0.0050±0.0025 MM THICK TIN. FOR MATERIALS CONTAINING 10% OR MORE ZINC, AN UNDERPLATE OF COPPER 0.0050±0.0025 MM THICK IS REQUIRED.

MATING BLADE INFORMATION
 SCALE 8:1

- NOTES:**
- UNLESS OTHERWISE SPECIFIED AND/OR INDICATED: DIMENSIONS ARE TO FACE OF VIEW SHOWN AND AUTOMATICALLY ROUNDED BY COMPUTER FOR INSPECTION. (SEE MATH MODEL FOR PRECISE DIMENSION) FOR ALL OTHER DIMENSIONS NOT SHOWN BUT REQUIRED FOR TOOL BUILD, SEE MATH MODEL FOR PRECISE TOOL PATH DATA.
 - MATING COMPONENTS:**
 CONNECTOR USE 12162102 OR EQUIVALENT
 TERMINALS - CAVITIES USE 12048074 TERMINAL OR EQUIVALENT
 ASSEMBLY USE 12048086 CABLE SEAL OR EQUIVALENT
 ASSEMBLY USE 12047948 SECONDARY LOCK OR EQUIVALENT
 ASSEMBLY USE 12020833 CONNECTOR POSITION ASSURANCE OR EQUIVALENT
 - WHEN PARTS ARE SHIPPED, THEY MUST BE PACKED IN PLASTIC BAGS OR SHIPPING CONTAINERS MUST BE LINED WITH PLASTIC LINERS. BAGS OR LINERS MUST BE SEALED TO AVOID ENTRY OF FOREIGN MATTER.
 - SEALING CODE 3**
 DESIGN WILL PASS SALT FOG AND IMMERSION TEST AFTER CONDITIONING AS SPECIFIED IN ESA-644 (WEATHER-PACK), ESA-710 (METRI-PACK), ESA-650 (UNDERWOOD MICRO-PACK), C-4006 (WORLD CONNECTOR), ETC. - WHEN MATED TO MATING PART OR EQUIVALENT
 - CONNECTOR ENGAGE FORCE CODE**
 - FOR PART NUMBERS WITH ADHESIVE, USE PM003510 OR ADHESIVE APPROVED BY MATERIALS ENGINEER TO GLUE CONNECTOR SEAL TO CONNECTOR.

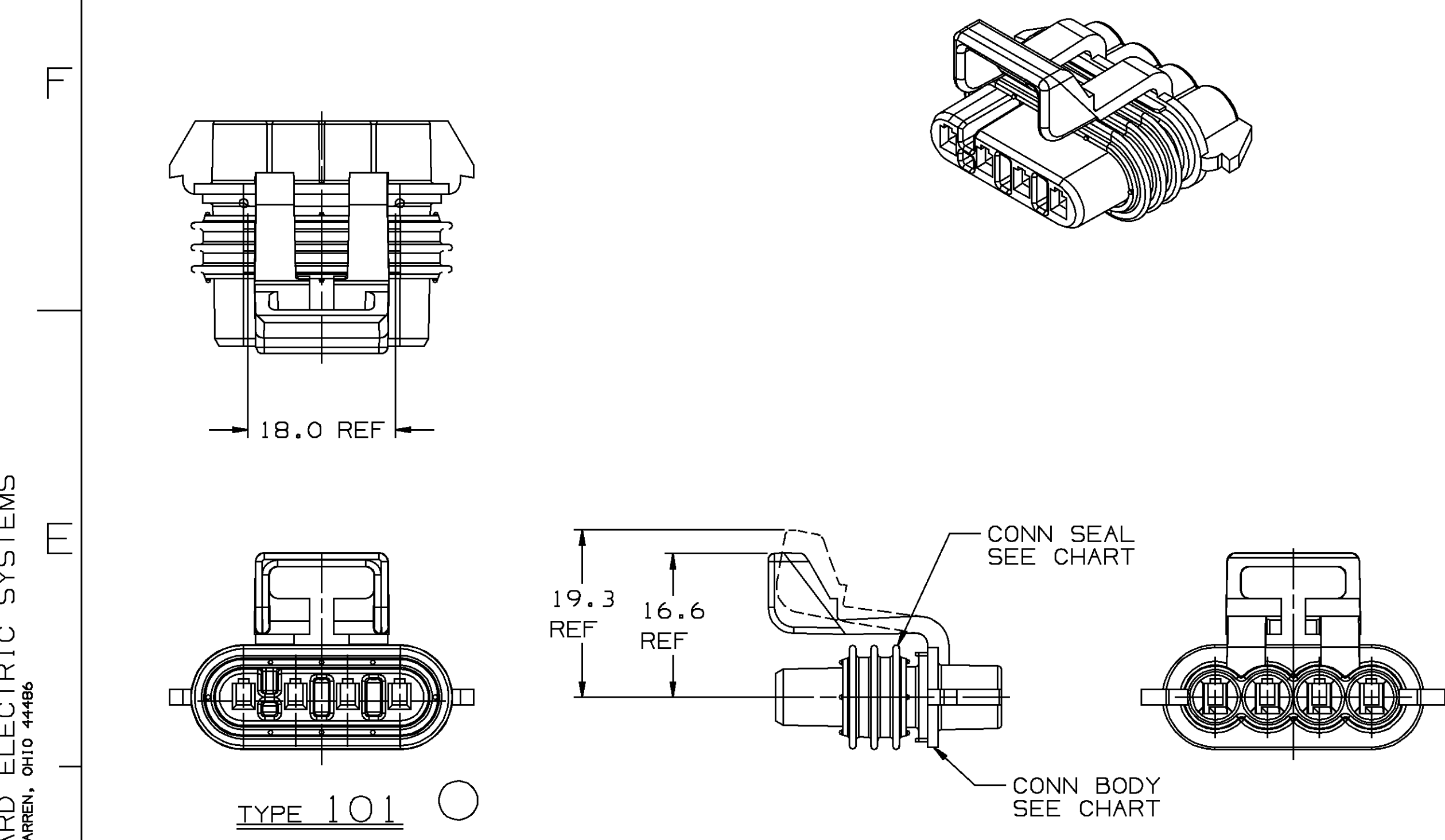

PREFERABLE LOCK ARM CONSTRUCTION

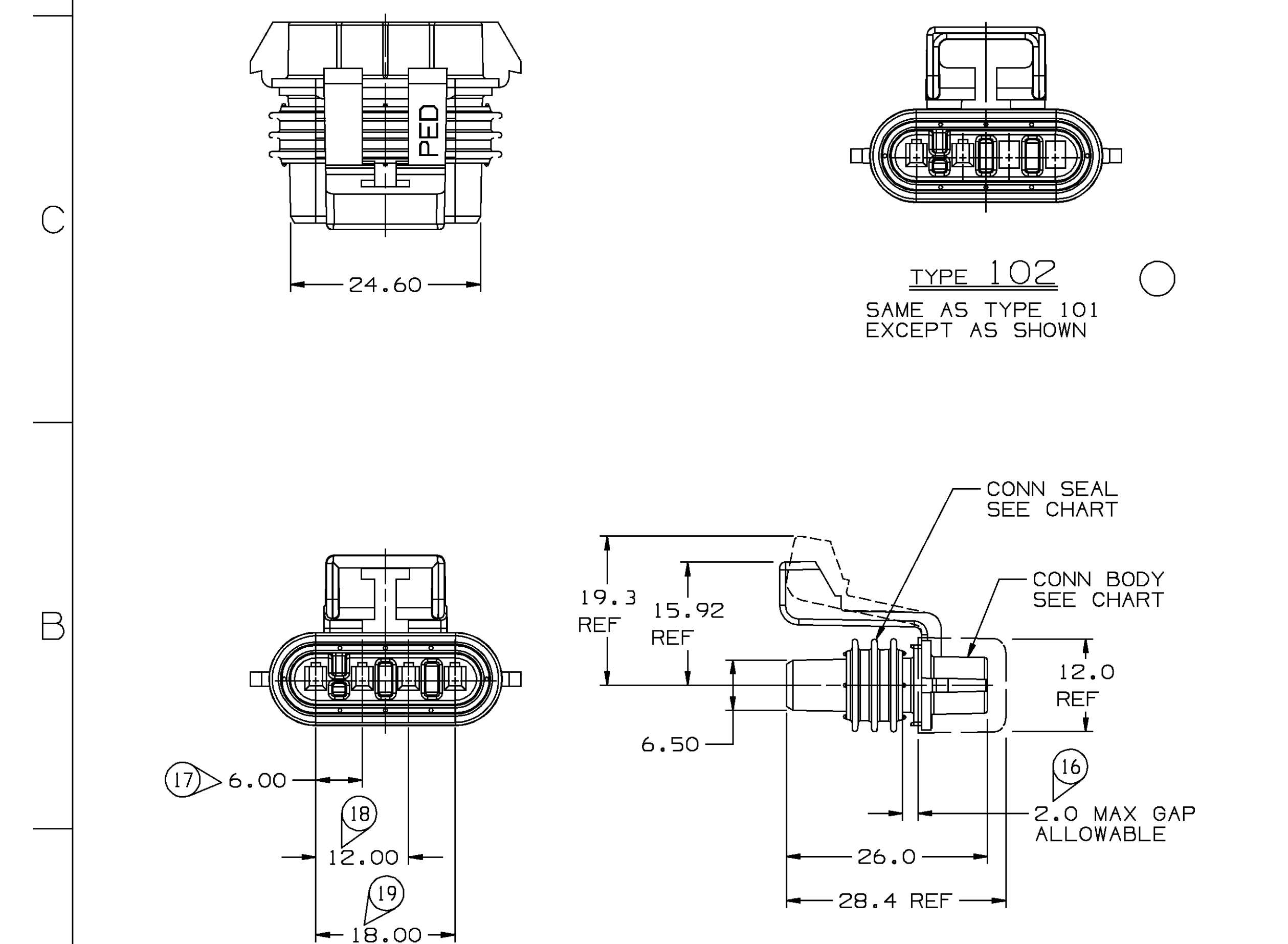

ALTERNATE LOCK ARM CONSTRUCTIONS

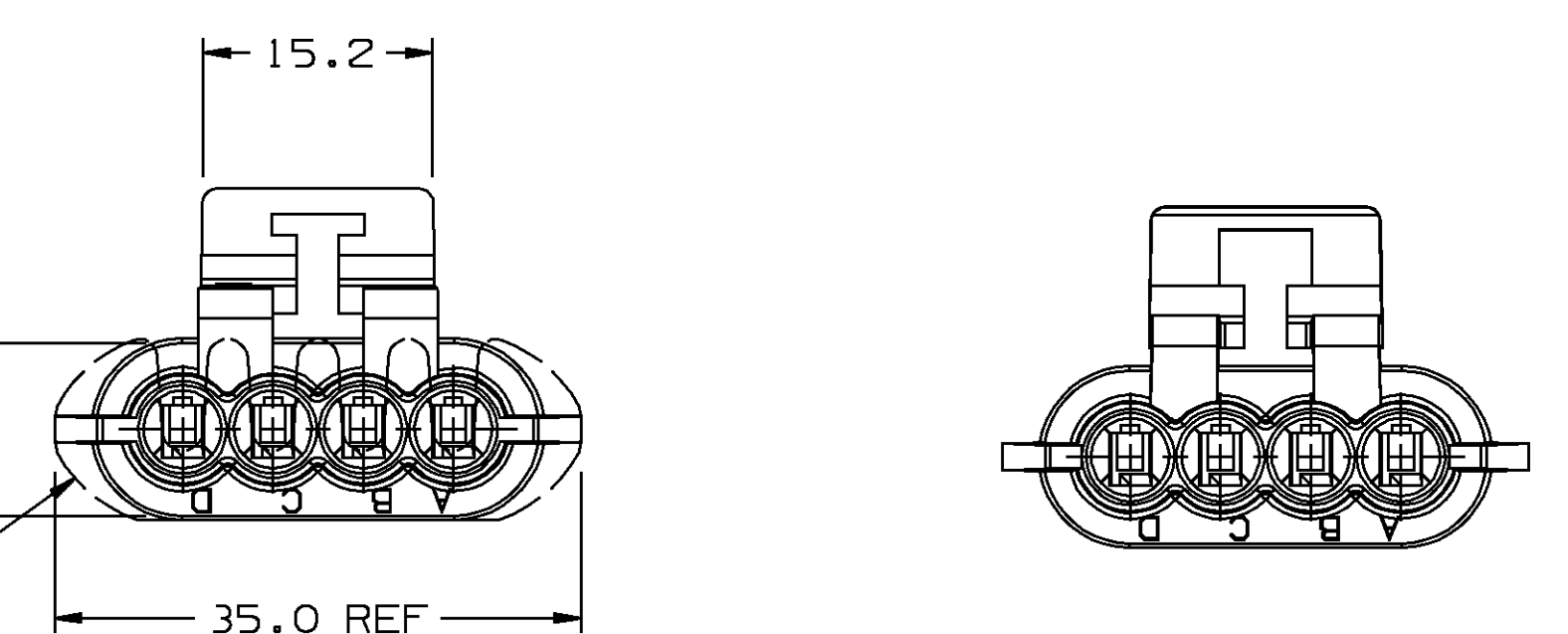
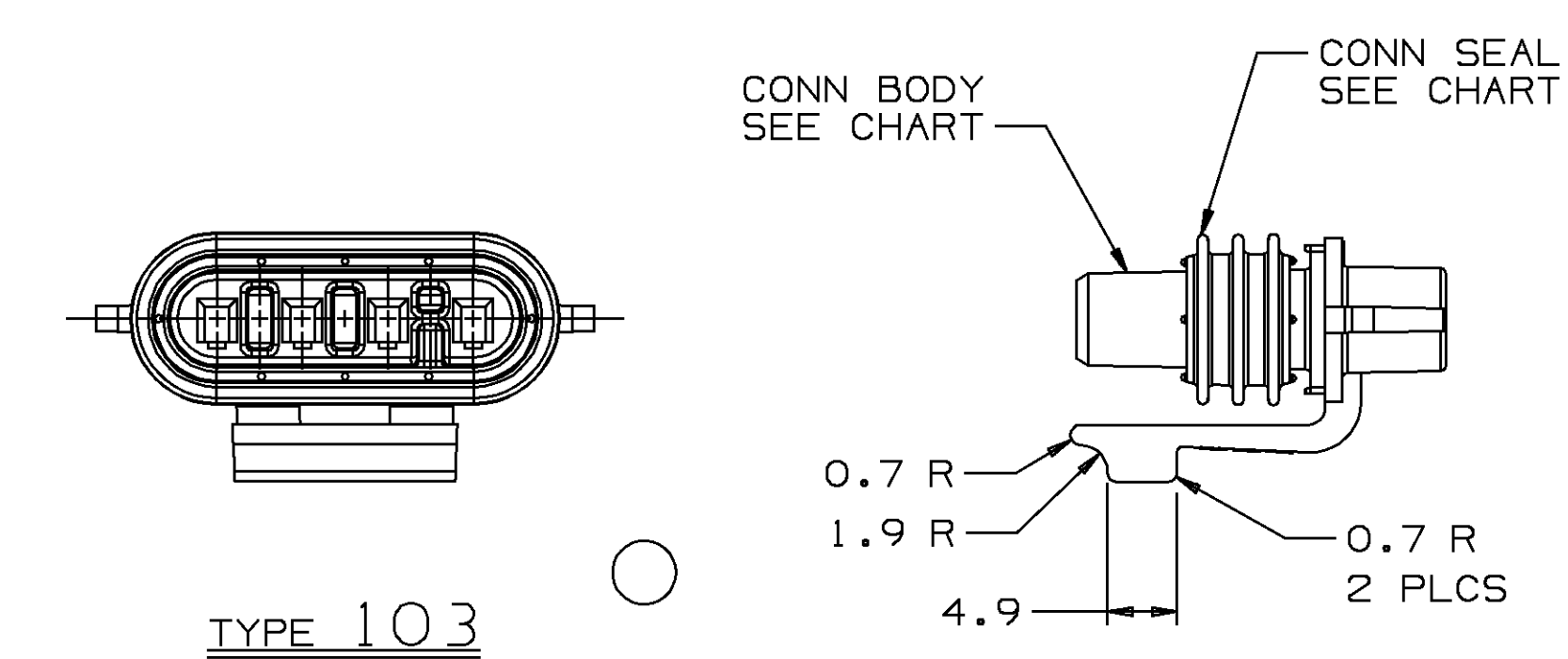
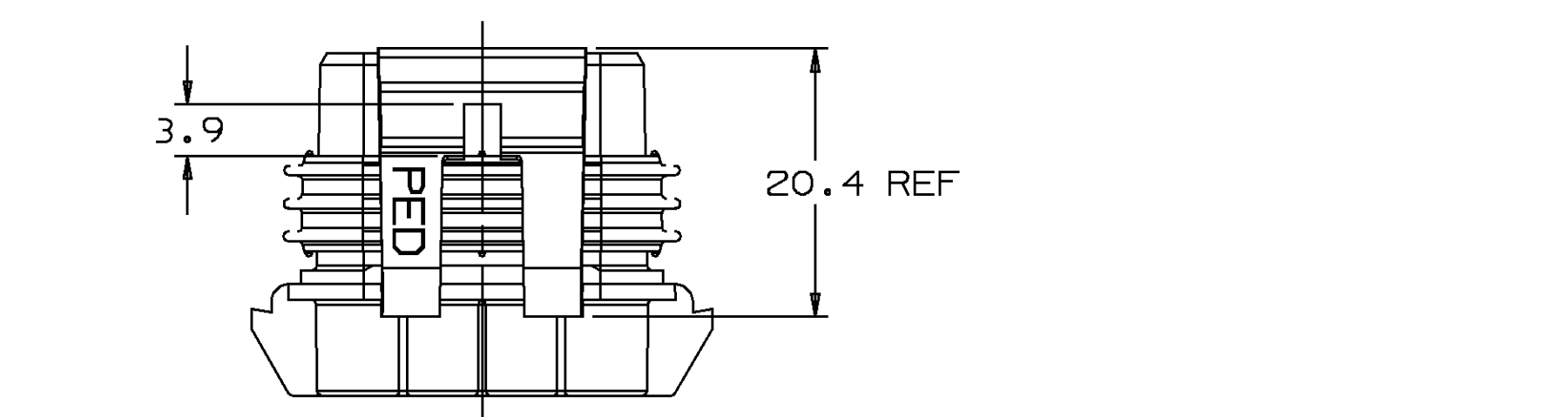

THE SECONDARY LOCK IS NOT PART OF THE CONNECTOR AND SEAL ASSEMBLY. IT IS SHOWN TO SHOW THE OVERALL SIZE OF THE CONNECTION.

ALTERNATE II

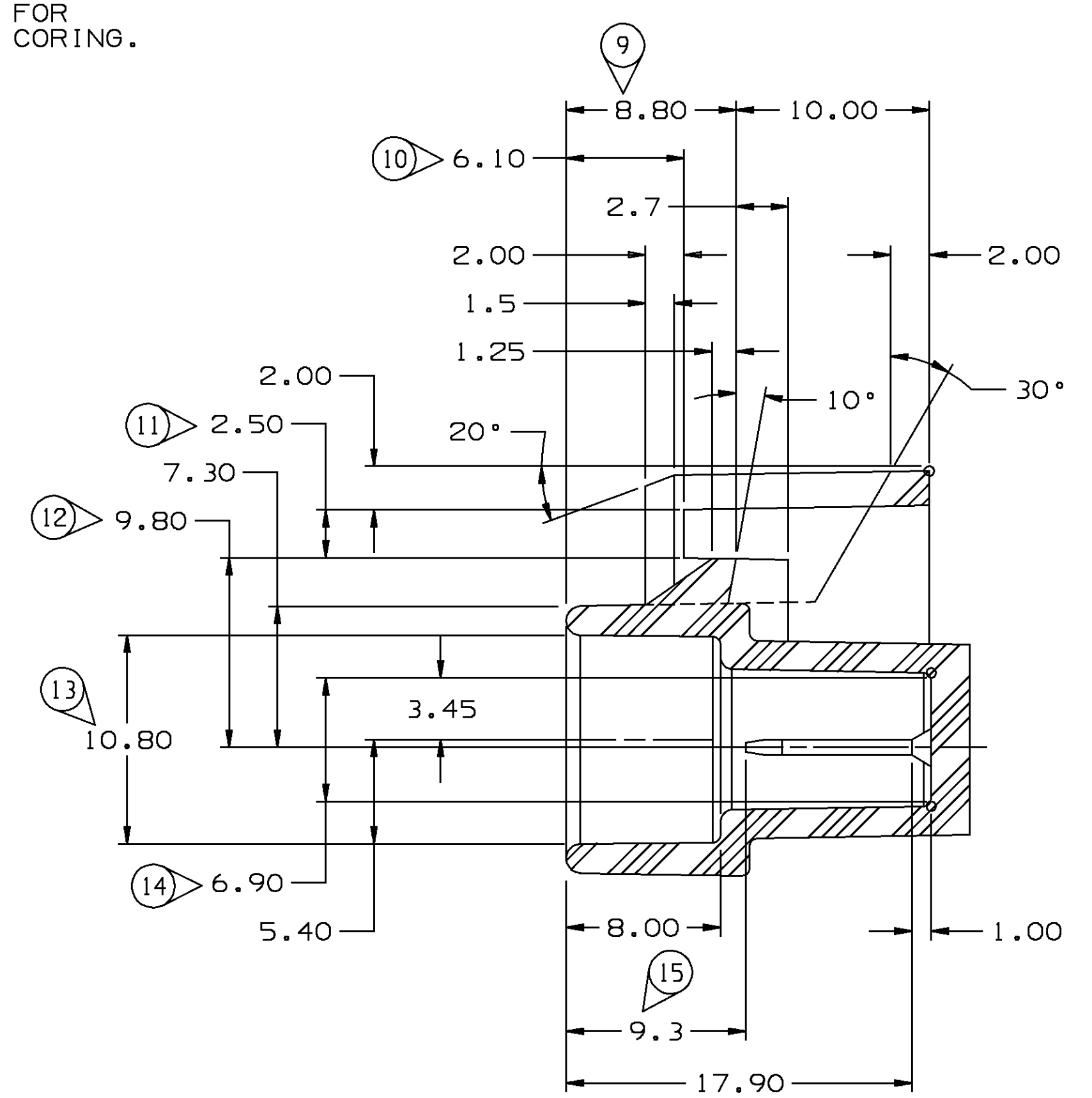
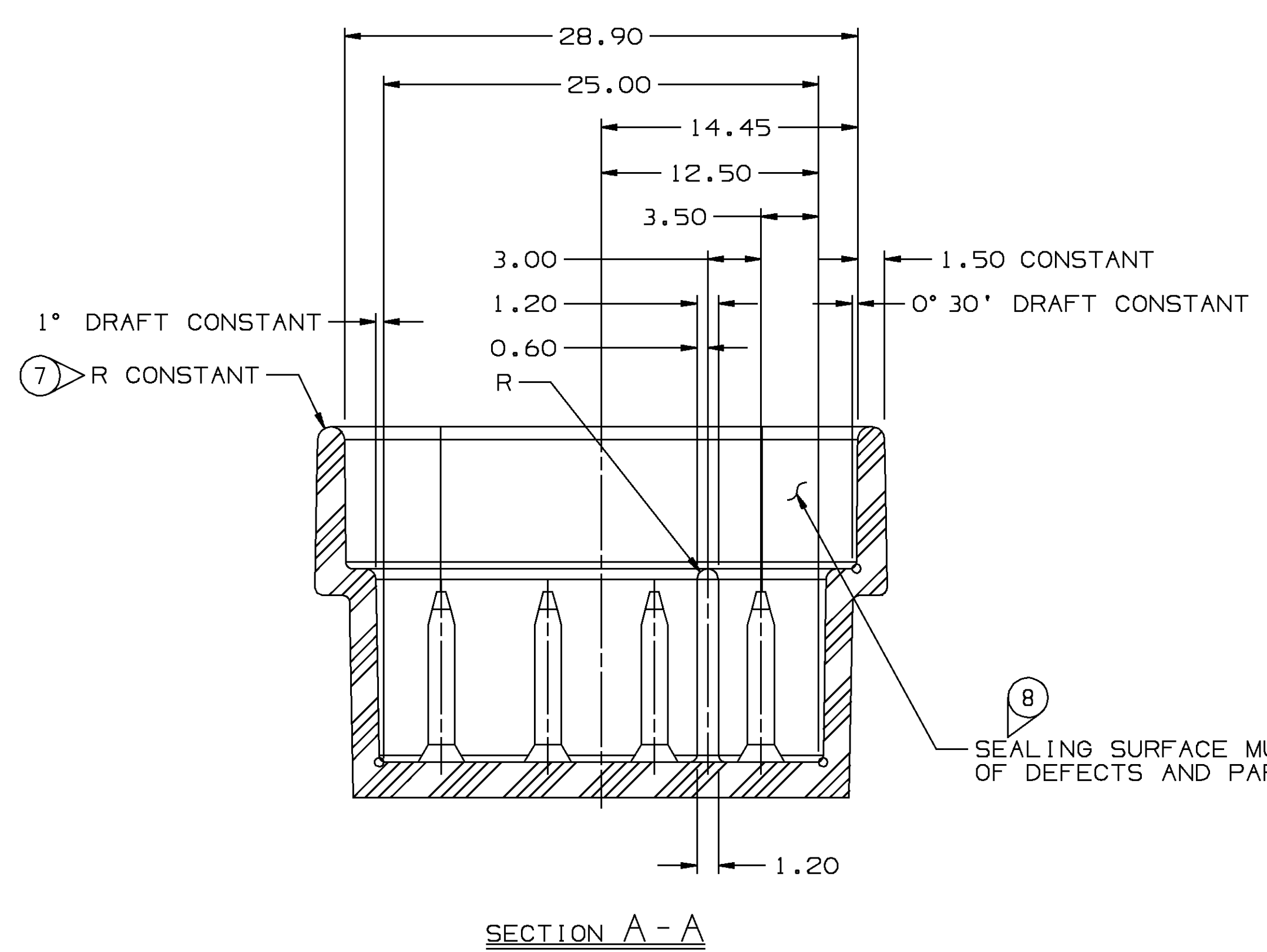
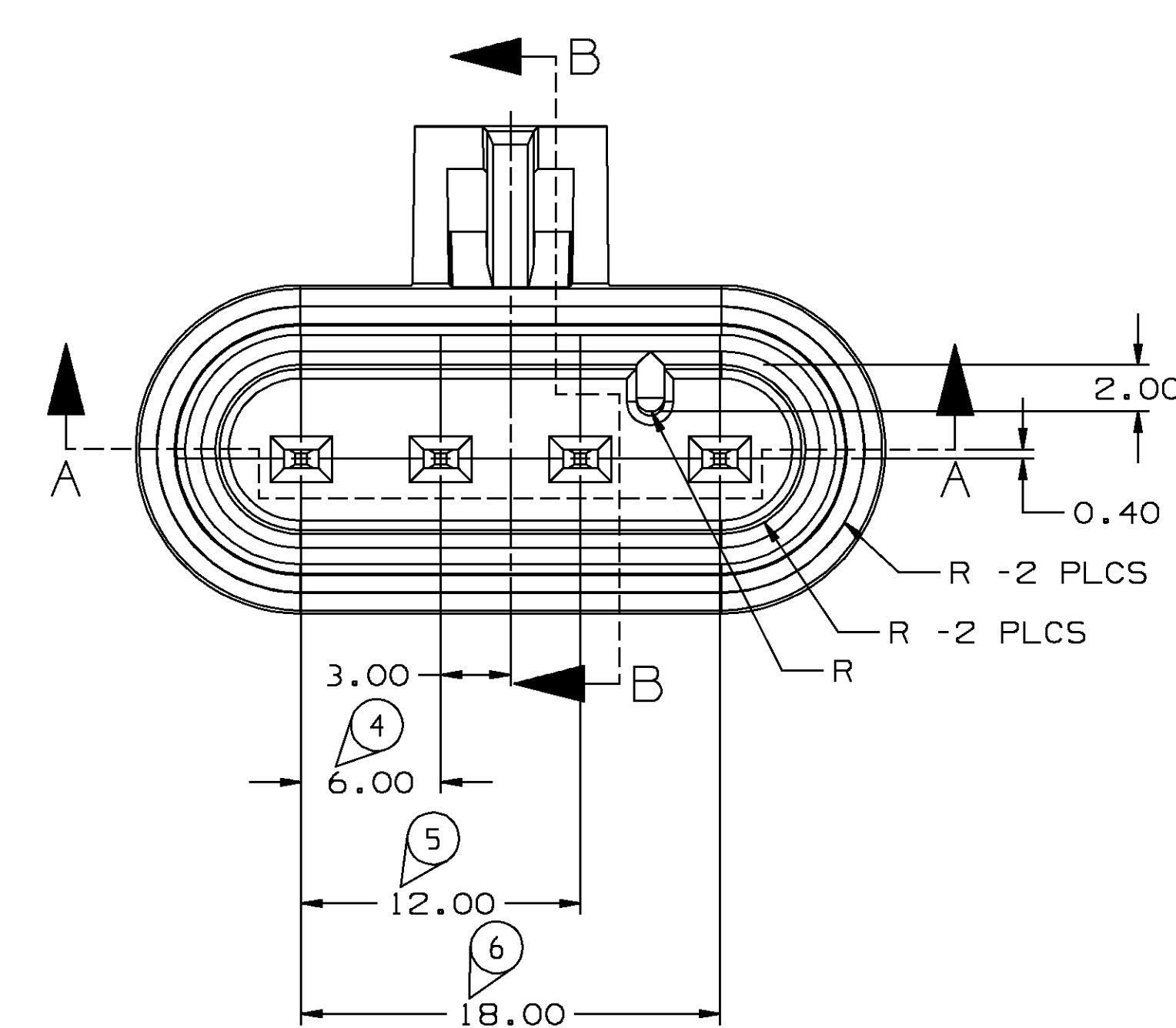
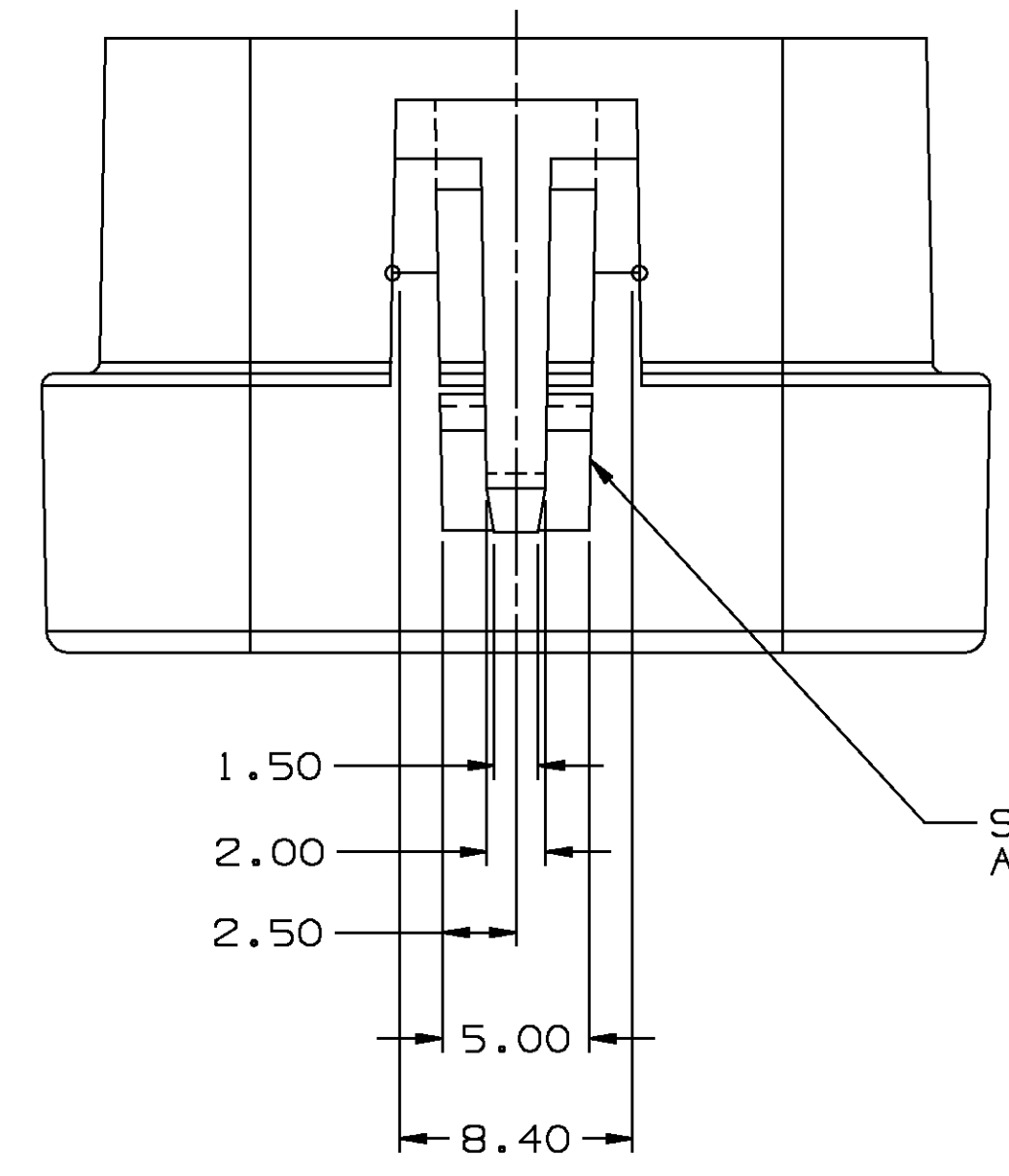

- NOTES:**
- UNLESS OTHERWISE SPECIFIED AND/OR INDICATED: DIMENSIONS ARE TO FACE OF VIEW SHOWN AND AUTOMATICALLY ROUNDED BY COMPUTER FOR INSPECTION. (SEE MATH MODEL FOR PRECISE DIMENSION) FOR ALL OTHER DIMENSIONS NOT SHOWN BUT REQUIRED FOR TOOL BUILD, SEE MATH MODEL FOR PRECISE TOOL PATH DATA. ALL RADII 0.40 DRAFT IS 1° ON ALL OUTSIDE SURFACES
 - RECOMMENDED MATERIAL - GLASS FILLED NYLON OR POLYESTER.
 - WHEN USING THIS INFORMATION FOR A NEW DESIGN, REQUEST THE LATEST COPY OF THIS PRINT FROM PACKARD ELECTRIC DIVISION.

MATING CONNECTOR INFORMATION
 SCALE 4:1

PART NO WITH ADHESIVE	REV	STATUS	TYPE	PART NO WITHOUT ADHESIVE	REV	STATUS	CONN BODY	CONN SEAL	REPLACED BY
			103	15324263		A	15324262	12047949	
			102	12186953		A	12186952	12047949	
12186694	A		101	12162144		A	12162143	12047949	
			101	12059870		A	12059869	12047949	12162144

SNOWCONE CHARACTERISTICS

DATE	SYM	REVISION RECORD	AUTH	DR	CK
02FE94		12059870 - ADDED TO TAXI			
		FROM SEPARATE DWG - REV.			
		REMAINS AT "A"	157861	JS	JS
02FE94		12162144 - RELEASED TO			
		REV. "A"	940005	JS	JS
02FE94		12059870 - OBSOLETE	940003	JS	JS
12MY94		CREATED SHEET 2	160647	RRS	SMF
120C94		ALL PARTS-ADDED ALT.			
		LOCK ARM CONSTRUCTION:			
		NO REV UPDATE REQ'D	163093	JOS	DLB
29JUN95		ADDED NOTE #6	167523	MRA	MAV
31JUL96		12186694 - RELEASED TO			
		REV "A" - REVISED NOTE			
		#6	960005	RRP	RPC
16JA97		12186953 - RELEASED TO			
		REV "A" - REVISED NOTE 1	970005	SEM	JVS
21JA98		15324263 - RELEASED TO			
		REV "A"	980005	AM	JIB
15DE98		ALL PARTS - ADDED TYPE			
		LABELS - OBSOLETE PARTS			
		REMAINS OBSOLETE - NO			
		REV UPDATE REQ'D	188808	BMC	BMC

DATE	SYM	REVISION RECORD	AUTH	DR	CK
02FE94		12059870 - ADDED TO TAXI			
		FROM SEPARATE DWG - REV.			
		REMAINS AT "A"	157861	JS	JS
02FE94		12162144 - RELEASED TO			
		REV. "A"	940005	JS	JS
02FE94		12059870 - OBSOLETE	940003	JS	JS
12MY94		CREATED SHEET 2	160647	RRS	SMF
120C94		ALL PARTS-ADDED ALT.			
		LOCK ARM CONSTRUCTION:			
		NO REV UPDATE REQ'D	163093	JOS	DLB
29JUN95		ADDED NOTE #6	167523	MRA	MAV
31JUL96		12186694 - RELEASED TO			
		REV "A" - REVISED NOTE			
		#6	960005	RRP	RPC
16JA97		12186953 - RELEASED TO			
		REV "A" - REVISED NOTE 1	970005	SEM	JVS
21JA98		15324263 - RELEASED TO			
		REV "A"	980005	AM	JIB
15DE98		ALL PARTS - ADDED TYPE			
		LABELS - OBSOLETE PARTS			
		REMAINS OBSOLETE - NO			
		REV UPDATE REQ'D	188808	BMC	BMC

DETAIL TYPE
 DETAIL/CPAD/PID

OTHER DRAWINGS AVAILABLE

Utrigraphs II

THIRD ANGLE PROJECTION

CODE NO: 6900
 GC: -C-5110

DWG DATE: 02FE94
 SCALE: 2:1

REFERENCE NO:

MATERIAL SPEC
 SEE DRAWING

NAME
 TAXI ASM CONN 4F M/P 150

PART NUMBER
 1216 2152

SIZE
 A0

SHEET 1 OF 2

DELPHI PACKARD ELECTRIC SYSTEMS
 WARREN, OHIO 44460