

REV
C 1027-001-002-0800-0800

REVISIONS			
SYM	DESCRIPTION	DATE	APPROVED
NC	NEW RELEASE PER E.O. P15950	4/20/99	R.D.R.
A	REVISED PER E.O. P16210	11/19/99	R.D.R.
B	REVISED PER E.O. P17504	12/10/01	R.D.R.
C	REVISED PER E.O. P20851	3-25-11	RDR

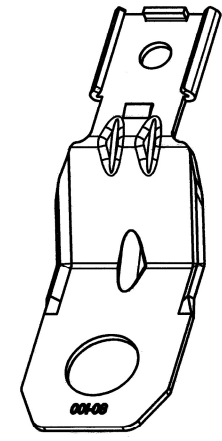
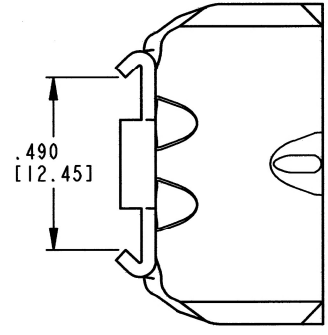
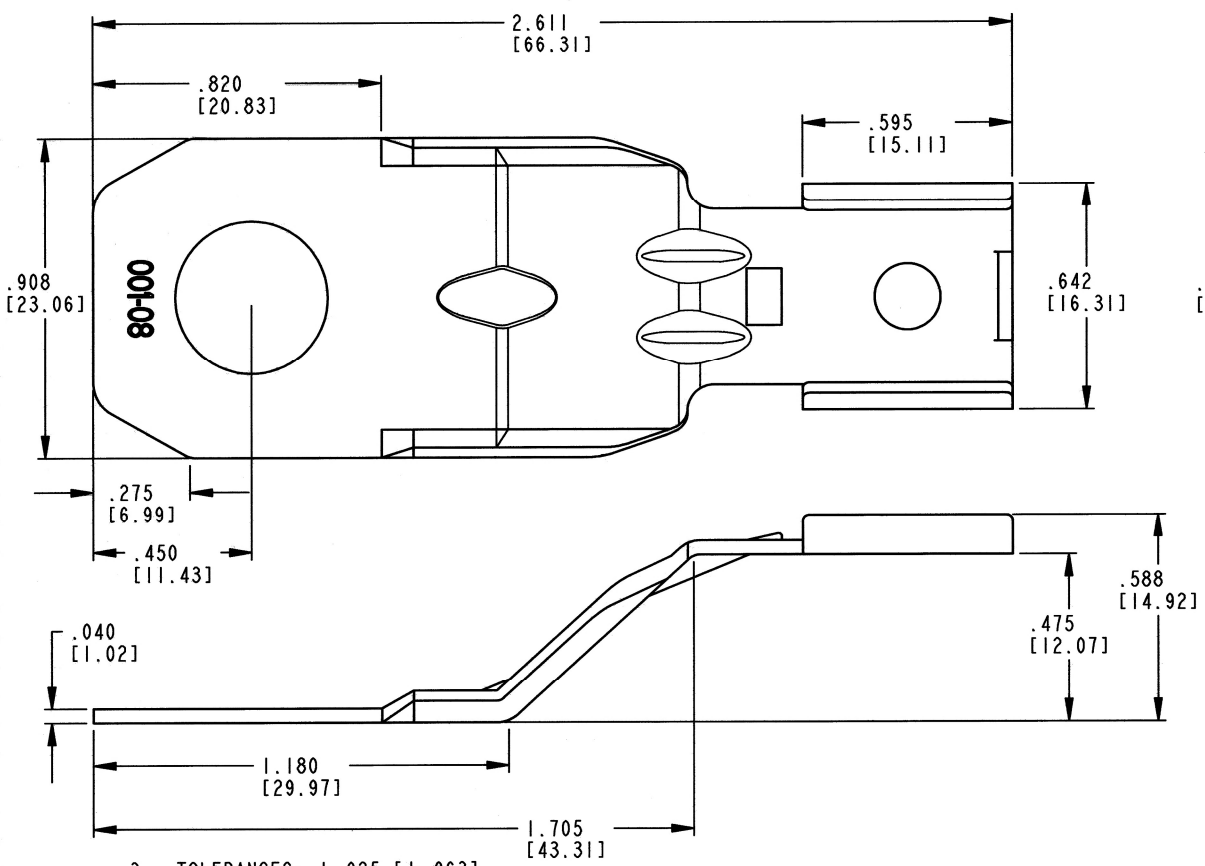

3D VIEW

3. TOLERANCES: ±.025 [±.063].

2. PART INFORMATION:

PART NUMBER	MATERIAL	HOLE DIAMETER
1027-001-0800	STAINLESS STEEL	.433 [11.0]
1027-002-0800	STEEL-ZINC PLATE	.512 [13.0]
1027-006-0800	STAINLESS STEEL	.512 [13.0]
1027-014-0800	STEEL-ZINC PLATE	.323 [8.2]

NOTES: 1. DIMENSIONS ARE IN INCHES (MILLIMETERS).

SIGNATURE & DATE	
DR	S. THEIS 11/09/99
CHK	[Signature] 3/23/2011
PE	A. Wynn 7/15/11
APPD	[Signature] 3/18/11
SCALE	NONE WT

METAL CLIP/
MOUNTING BRACKET
FOR 8 WAY RECEPTACLE
DT SERIES

ENVELOPE

EP	MATL. CODE
	3850 INDUSTRIAL AVE. HEMET, CA 92545
B 1027-001-002-0800-0800	
DWG SIZE	SHEET OF
11139	